

What's Inside:

- Shadetree Mechanic
- Trip Report (Calico)
- Members Alley
- Tips & Tricks

Upcoming Events

- February 5th Lance Chat
- March 5th Lance Chat
- April 2nd Lance Chat
- April 4-6 Lance Owners Rally BBQ and Factory Tour

Lance Owners of America Newsletter



Presidents Report

I hope everyone had a great holiday and a happy new year. The LOA is looking forward to another great year in 2003. If you have not checked out the new 2003 model year Lance Campers then go to the Lance website or write to Lance for a catalog because they are truly amazing.

Every year Lance keeps on improving their designs and making a better camper. I am glad to see a change in the refrigerator for the 2003 models. If you have not heard, Lance will only be putting Norcold refers in their 2003 models.

I would like to also

say welcome and thank you to all of our new members. We are steadily growing and it is you, the members, who make that happen.

Lance Owners of America Rally 2003

The 2nd annual Lance Owners of America factory Tour and BBQ will be held on Friday April 4th. We will be camping at the Thousand Trails Soledad Canyon campground in Acton in the group area. The price for camping will be 27.00 per night per site. The facility is a very nice, full hookup campground with swimming pools, rec room, mini golf

and many other activities to keep you busy. If you plan on attending please send in your camping fees to the Lance Owners of America by March 5th 2003. Last year we all had a really great time at the campout and factory tour. There is much to be learned from the Lance Staff as well as other owners of Lance Campers. Payment for this

event is now available by credit in the Lance Owners of America online store. Simply go to the LOA website and click on "Online Store".

We at the LOA look forward to meeting you all at the rally and finally putting some faces with names from the website.

The Lance Glance

Schedule for Lance Owners Rally/BBQ/Factory Tour

Thursday April 3rd LOA arrives at campground at 12:00 noon

Friday April 4th Caravan to the Lance Factory at 3:00 pm

Friday April 4th Lance Factory Tour 4:00 pm

Friday April 4th BBQ at Lance Factory at 5:00 pm

Friday April 4th Head back to camp after dinner

Saturday April 5th Pancake Breakfast provided for all LOA members.



Campground Information

Thousand Trails Soledad Canyon
4700 Crown Valley Road
Acton, CA 93510



27.00 Per Night Full Hookups

Please Mail Pre-registration by March 5th

Make checks payable to:

Lance Owners of America

PO Box 52363

Irvine CA 92619-2363

Payments are accepted by Credit Card in the LOA Online Store.

Directions to Thousand Trails Soledad Canyon

If you are coming from HWY 14 South

Exit Crown Valley Road in Acton California

Turn Left off of the Freeway and follow Crown Valley Road for about two miles through town to a stop sign. Go through the intersection, over the railroad tracks and follow the road to the campground on your left.

If you are coming from HWY 14 North

Exit Crown Valley Road in Acton California

Turn Right off of the Freeway and follow Crown Valley Road for about two miles through town to a stop sign. Go through the intersection, over the railroad tracks and follow the road to the campground on your left.

Trip report: Calico 2002 November

My family and friends all decided that we would celebrate Thanksgiving in the California desert at the Calico Ghost Town Campground. I was very surprised to see how nicely maintained the campground was. Clean bathrooms and friendly staff always makes for a good stay. The sites were very large and all dirt but the hookups were new and modern. The weather was excellent for us on Thanksgiving day but we got some scattered showers the rest of the weekend. There was plenty of activities to keep us busy the whole time like hiking, exploring mines and browsing through the ghost town. The ghost town is not very ghostly but more commercial with gift shops exhibits and shows. 1881 Marked the beginning of one of the largest silver strikes in California history and the birth of Calico. This authentic silver mining town lives on as one of the few original mining camps of the Old West. One third of the town is original; the remaining carefully reconstructed to recreate the "spirit" of Calico's Old West past. Walking tours with Calico's historian examine the life of miners, the famous 20-mule team, and a U.S. Postal mail dog, named Dorsey. A narrow gauge railroad operates within town limits and a hardrock silver mine offers up underground exploration.

This trip has all the makings of a tradition in my family and we will probably be back next Thanksgiving.

Calico Ghost Town
P.O. Box 638
Yermo, CA. 92398
1-760-254-2122
1-800-TO-CALICO
Fax 1-760-254-2047

Camping Per Night

- Non Hookup..... \$18
- Full Hookup..... \$22
- Partial Hookup..... \$21
- Camping Cabins.... \$28

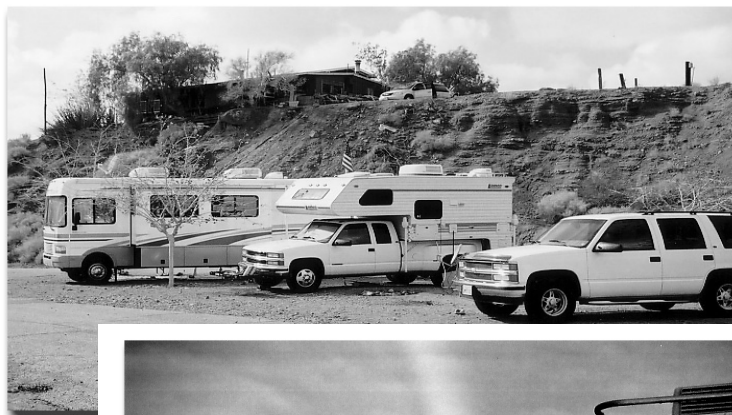

I guess you can find happiness at the end of the rainbow.

The Lance Glance

Shadetree Mechanic

Shadetree Mechanic

The Shadetree Mechanic is all about the things you can do in your own garage even if you're not a real mechanic. In this article we will be exploring a common problem Dometic refrigerators, the "Check Light".



"If you have a question, comment or idea for the Shadetree Mechanic send it to: shadetree@lanceowners.com."

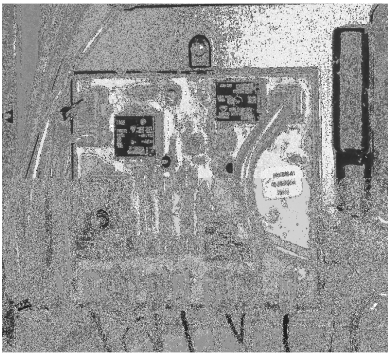

Above: Dometic stock board.
Below: P 711 installed

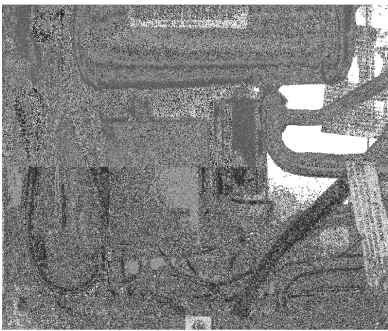

If you have ever had your "**Check**" light illuminate on your refer during travel or just for no reason at all then you should read this. This is a well know problem that has plagued many of us on our Dometic RV refrigerators. Let me explain the symptoms. You turn on your refrigerator a day before you are getting ready to leave on a big trip. At some point the "**Check**" light comes on and your refer has stopped cooling. Many people think it is a pilot flame being blown out or poor gas supply. It could be either of these but the odds are pointing towards a ground loop caused by a poorly designed circuit board in the Dometic refrigerator.

What can we do about this problem?

If your camper and refer are still under warranty then I recommend you take it to the dealer and let them fix it. Have them replace the circuit board from Dometic. I attempted to contact Dometic about this problem and was ignored so they will be no help if you are out of warranty. If you are even remotely proficient with tools and electronics then you can fix your refrigerator yourself.

I bought an aftermarket circuit board called a P-711 from Dinosaur electronics. It is designed especially for Dometic refers and corrects the problem described above. It cost about 100.00 shipped and came to me in three days. I bought it at www.rvmobile.com and the service was absolutely great.

The instructions that come with the Dinosaur P-711 are very good and easy to follow. I am not going through the installation process in this article but I will give an overview.

Dinosaur P-711

The P-711 is an after market circuit board made by Dinosaur Electronics that is a replacement for all of the second generation main circuit boards. It has a special thermocouple circuit, proven dependability, and a three year warranty. The P-711 fits models with the old or new wiring, and with or without a new wire harness. In other words, it fits all of the second generations models no matter what.

The P-711 has all the features of the original Dometic plus a few more, which are listed at the bottom of this page. Because of the new thermocouple circuit, the P-711 has an extra terminal (J11) at the bottom of

the board. This is where the shorter wire of the thermocouple goes. The longer thermocouple wire goes to J3 where it's always been. A ground wire connecting J10 to the ground terminal is also required. On units with the old wiring, the ground wire already goes to J10. On units with the new wiring, you would need to add the ground wire. All other connections to the board are the same as the original.

Be sure to disconnect the 12 volt wiring and to unplug the 120 volt power cord before replacing the circuit board.

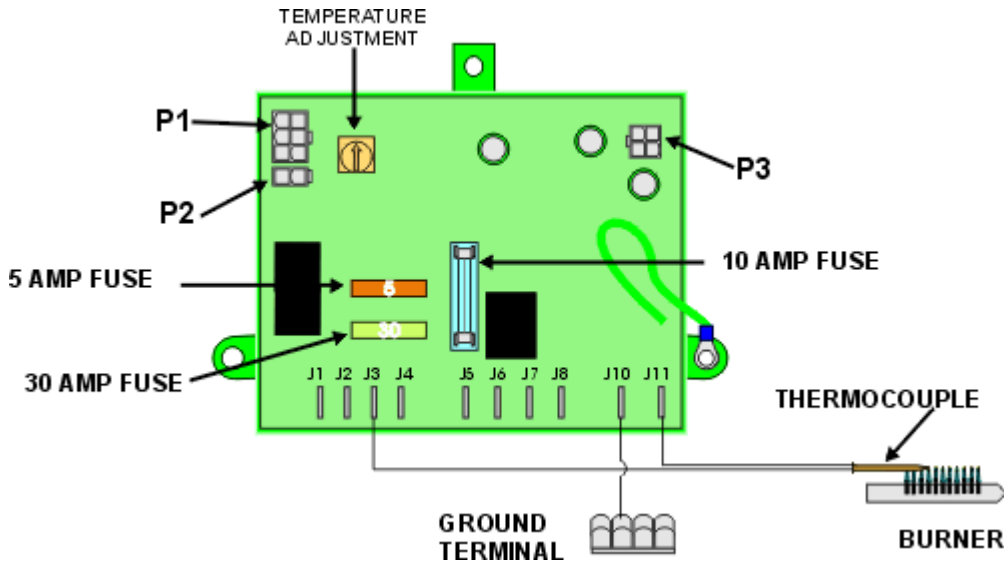

Terminal Connections

J1	12 Volt Element (for 3 way models)
J2	Interior Light
J3	Thermocouple
J4	12 volt positive (+)
J5	AC In
J6	AC In
J7	AC Out (120 Volt Element)
J8	AC Out (120 Volt Element)
J10	12 Volt Ground (-)
J11	Thermocouple

P1	Eyebrow
P2	thermistor
P3	Gas Valve & Igniter

5 Amp Fuse	Board Circuitry (12 Volt)
30 Amp Fuse	12 Volt DC Heat Element (Optional)
10 Amp Fuse	120 Volt AC Element

Extra Features

- Universal - Fits all second generation models - 2 way or 3 way.
- Temperature Adjustment - able to adjust temperature range, which would be especially helpful on fixed temperature models.
- If the gas flame fails to light and the check light comes on, the board will try to light every 30 minutes after that, instead of going into lock out.
- Improved thermocouple circuit eliminates ground problems.
- Automatic System Detection - detects the eyebrow type on the refrigerator and matches it.
- Surge Protection - 12 volt circuits are protected.
- No wiring kit is necessary.
- Connections are clearly marked on circuit board, making it easy to connect even if the paper work is lost.

Tips and Tricks

For you and your Lance Camper

Topic: Electric Jack Maintenance

We have received many requests for "What do I need to do about maintaining my Atwood Electric Jacks" so we looked into it. Lance and Atwood were our sources for this information. Both sources gave us the same information.

Page 3 of the Atwood Installation Guide The maintenance would be the same for either manual or electric jacks.

"Maintenance"

1. Internal parts of the jack are permanently lubricated at the factory and do not require any further lubrication.
2. At least once each camping season fully extend jacks and clean dirt and grime from the outside of the inner tube. Coat entire outside of inner tube with silicone spray lubricant. This will protect the finish of the inner tube and provide lubrication between the jack's tubes. Clean dirt and grime from the outer housing. Spray the alignment tube inside and out with silicone (fig 8-B & 17-A).

Note: If it is not possible to get jack to operate freely, replace jack.

3. Apply a good automotive polish or wax to the outer tube of the jack to maintain the appearance.
4. Should problems or questions arise, contact your dealer, the camper mfg., or the Atwood Service Department (815)-877-5700 .

Topic : Black Streaks From Gutter Run Off

Here is a tip to prevent the black streaks running down the side of your camper caused by the gutter. The front gutters usually let the water drip down the side of the camper near the front of the side cabover windows. You can clip a wooden clothespin on your gutter and point it slightly down and away from the camper. The water will saturate the clothespin, run out to the end of it and drip off. The water will fall to the ground without running down the side of your camper. If you get black streaks at other places down the side of your camper then you will need to make sure your gutters are not clogged with debris, leaves or any other foreign objects that cause runoff to spill over the side of the gutter.

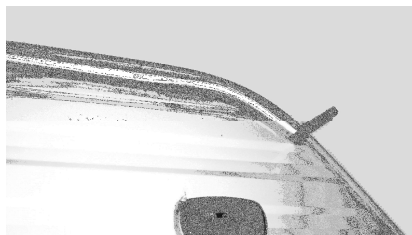

Enchiladas in the Lance

Steve's Recipe for Chicken Enchiladas

Ingredients

- 2 cups chopped cooked chicken
 - 1 cup chopped green bell pepper
 - 1 package (8 ozs) Philadelphia Cream Cheese (cubed)
 - 1 jar (8 ozs) salsa
 - 8 flour tortillas (6 inch are the best)
 - 3/4 lb. (12 ozs) Velveeta Cheese (cut up, cubed)
- You can also use the shredded cheese found at the grocery store to save time

Directions

1. Stir chicken, bell pepper, cream cheese and 1/2 cup salsa in saucepan on low heat until cream cheese is melted.
2. Spoon 1/3 cup chicken mixture down center of each tortilla; roll up. Place seam side down, in a lightly greased 12x8-inch baking dish.
3. Stir process cheese spread and milk in saucepan on low heat until smooth. Pour sauce over tortillas; cover with foil.
4. Bake at 350 degrees for 20 minutes or until thoroughly heated. Pour remaining salsa over tortillas and serve.

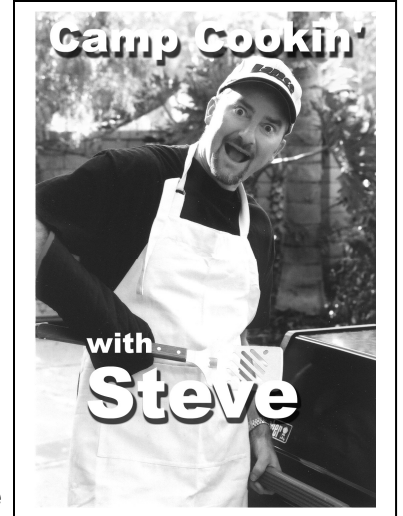

Members Alley

The members alley is designed for our members all over the country to send in photos and stories they would like to share. If you have something to send in mail to LOA PO Box 52363 Irvine, CA 92619-2363 or email to info@lanceowners.com.



Member Anna Little suffered some height related damage. They got the camper repaired and all is well now. Keep your head down Anna. =)



Here is Member Gordon taking his Lance through some seriously deep snow. He was actually stuck here for a short time but got out ok. Looks like a ton of fun.